



# *Recycling Material Identification Guide*



# Recycling of Lead-Acid Batteries at Exide Technologies

Lead-acid batteries received at Exide’s recycling facilities are shredded or otherwise disassembled, and the lead, casing and acid fractions are separated. Exide also handles sulfuric acid, converting it to sodium sulfate (a marketable material); reusing it on a limited basis; or neutralizing and discharging it as clean water. Shredded polypropylene casings are washed, sized, classified, melted and extruded to form polypropylene pellets used to manufacture new battery cases. The lead is recovered in furnaces and is reused for the manufacture of lead-acid batteries or as a raw material in other processes. Exide’s “vertically integrated” operations are designed to provide the best possible management option for recycling of batteries.

Exide Technologies is aware that some companies in the secondary lead recycling business may offer an environmental indemnity to Providers sending spent batteries for recycling. Exide Technologies believes that the Superfund law provides our Providers with a superior *exemption* from liability for batteries sent to Exide facilities. That statutory exemption may not apply to spent batteries processed at facilities owned by other companies.

Exide Technologies owns and operates secondary lead smelters for the recycling of spent lead-acid batteries and other lead-bearing materials. When batteries are returned to our secondary lead recycling facilities, they are recycled in a manner that ensures compliance with federal land ban regulations and state recycling laws. Our facilities operate under RCRA Part B Hazardous Waste Facility Permits issued by the U.S. Environmental Protection Agency and corresponding state environmental regulatory agencies, or under approved interim status awaiting final issue of such permits. Exide’s secondary lead recycling facilities are in the following locations:

Baton Rouge, LA*	US EPA ID #LAD008184137
Forest City (Canon Hollow), MO	US EPA ID #MOD030712822
Frisco, TX	US EPA ID #TXD006451090
Muncie, IN	US EPA ID #IND000717959
Reading, PA	US EPA ID #PAD990753089
Vernon, CA	US EPA ID #CAD097854541



\* Baton Rouge has temporarily ceased operations



*Exide's secondary lead recycling facilities are only permitted to process lead-acid batteries. All other batteries are considered "non-conforming" and will not be accepted.*

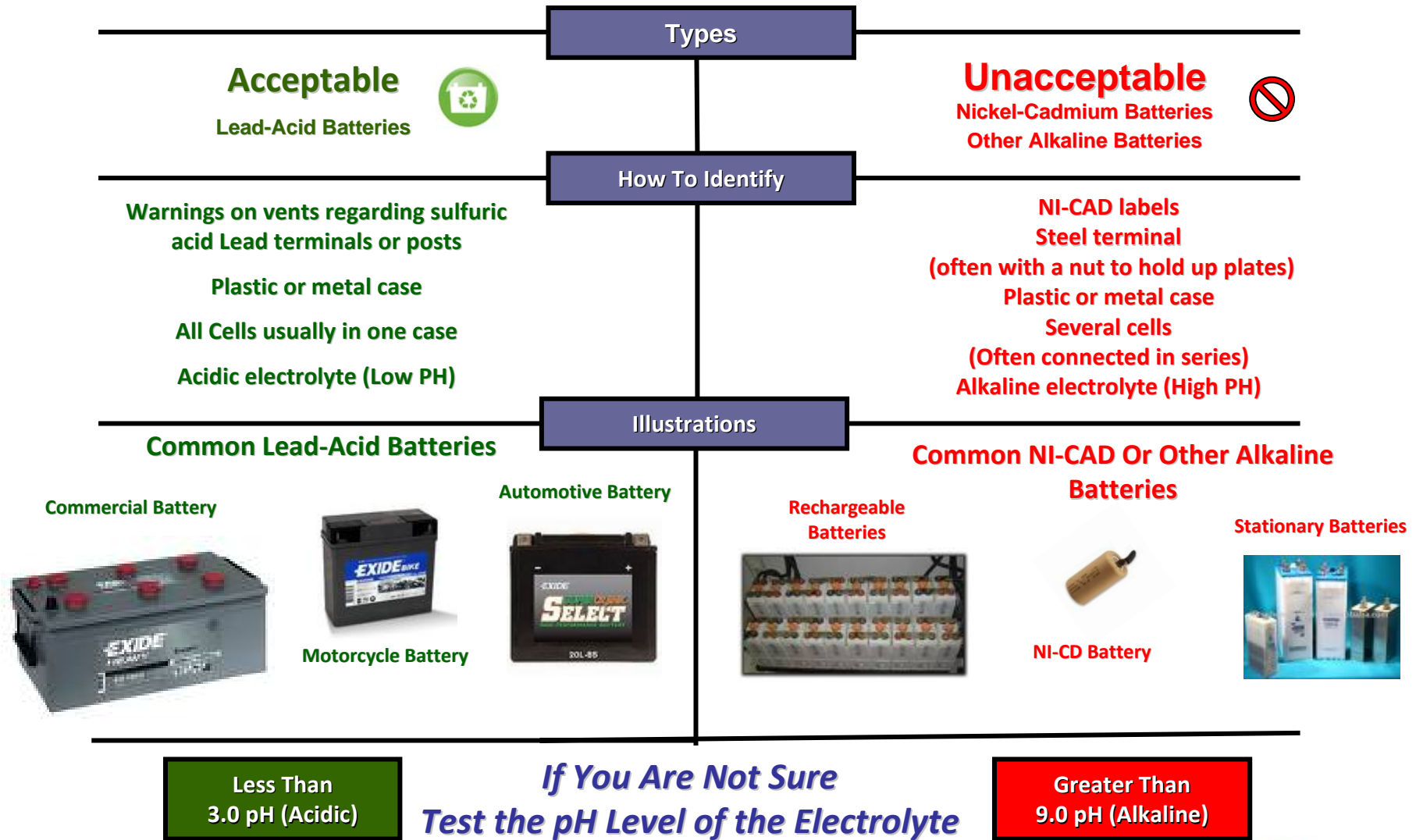



# Noncompliant Material



Exide Technologies owns and operates secondary lead smelters for the recycling of spent lead-acid batteries and other lead-bearing materials.

**Noncompliant materials** directed to an Exide Recycling Center affect everyone in many ways:

- permits do not allow for collection, storage or recycling of these items on site
- material “hidden” or “mixed” with compliant material may result in personal injury, damage or unscheduled shut down of equipment
- rejection of the entire load resulting in fines or incremental handling, freight and other charges assessed to the originator

Please inspect all loads prior to shipment to Exide and assure the material provided meets Exide specifications and requirements.

## Examples of Noncompliant Materials



Lithium  
Lithium-Ion



Alkaline



Metal  
Hydride



Al-Cad



Laptop



# Auto Battery Components

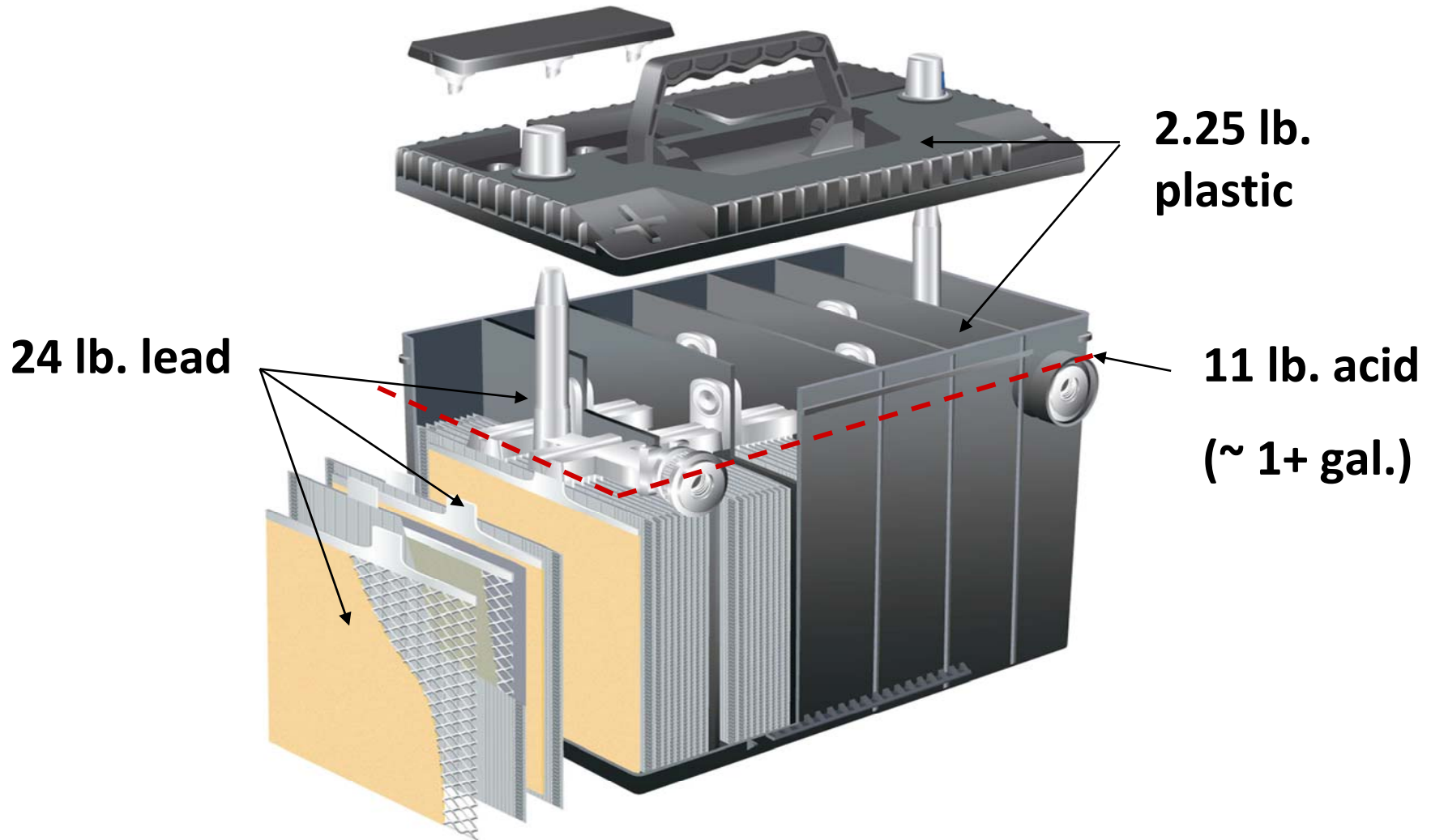

# Motive Battery Components

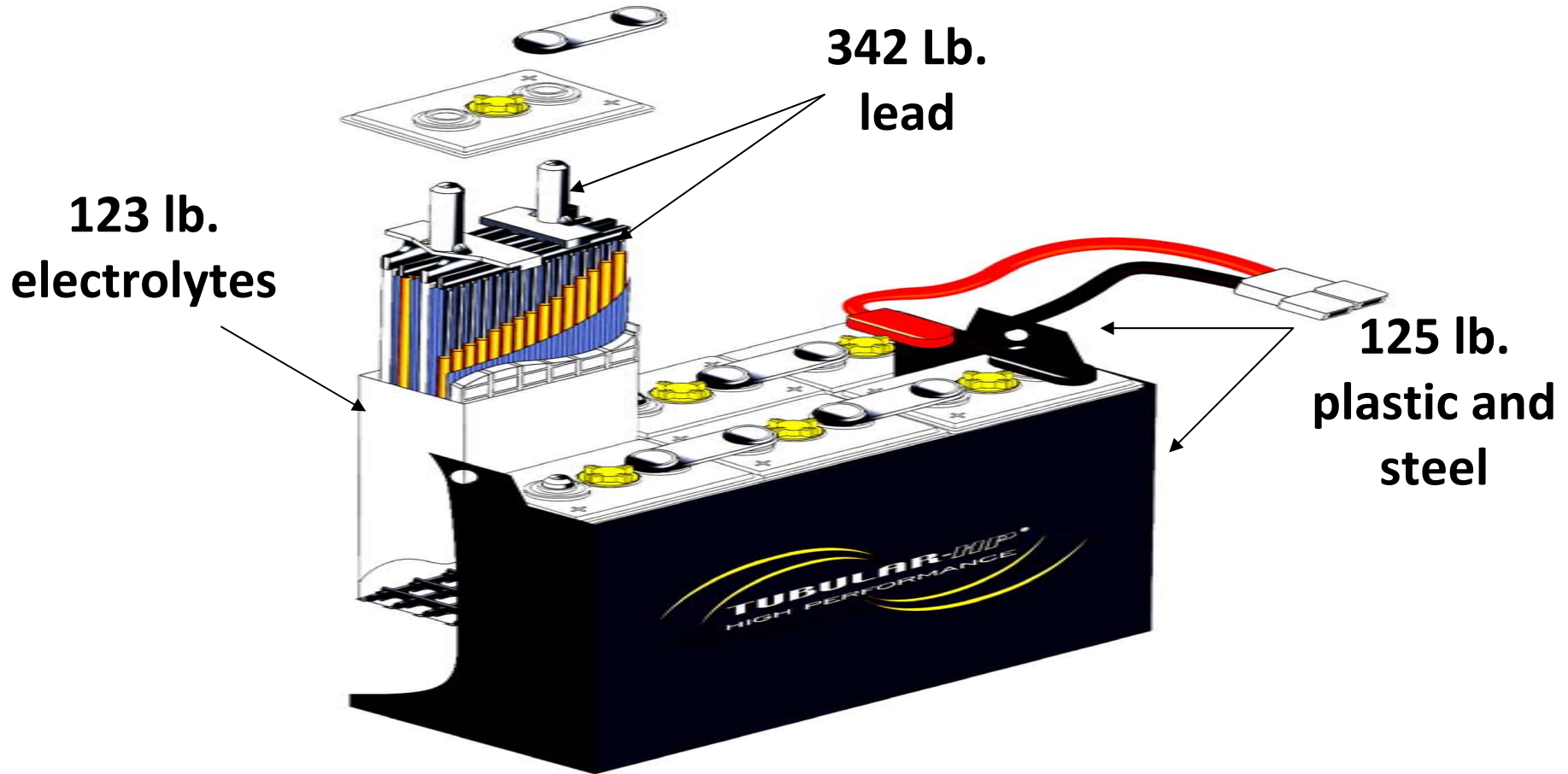

# Packaging and Securing Used Batteries / Cells

WAFFLEBOARD OR SHEETS OF CARDBOARD\*

BATTERIES

WAFFLEBOARD PREFERRED\*

(MINIMIZES POTENTIAL FOR PEST PENETRATION AND SHORT CIRCUIT)

BATTERIES

WAFFLEBOARD PREFERRED\*

(MINIMIZES POTENTIAL FOR PEST PENETRATION AND SHORT CIRCUIT)

BATTERIES

CARDBOARD

SKID BOARDS

RUNNERS

\* See Item 4 and 7 under Stacking Pallet Instructions

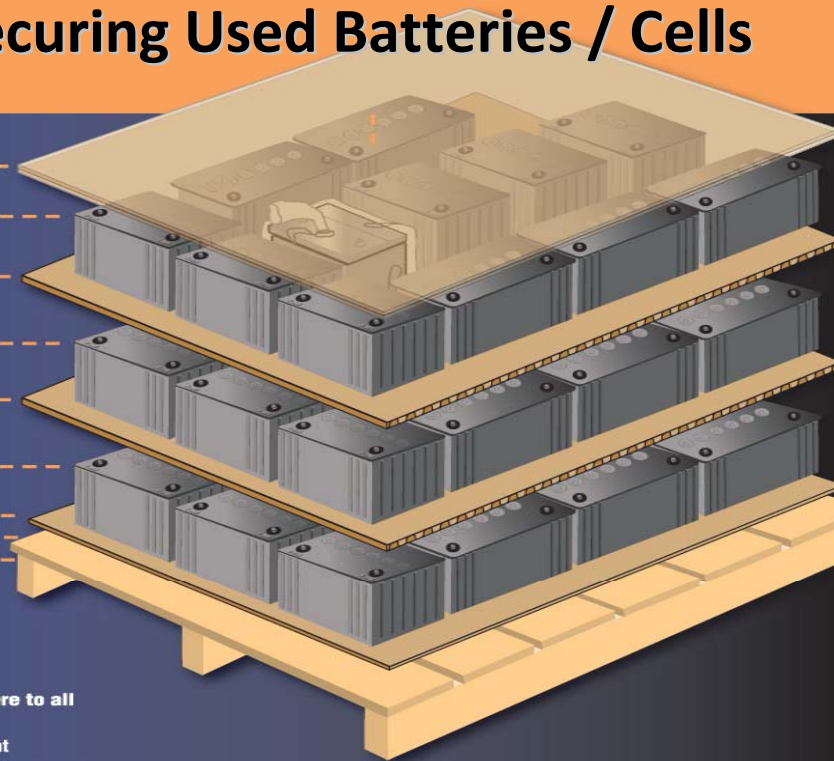

## IMPORTANT GENERAL HANDLING REQUIREMENTS

Before handling battery/cell(s), please read and adhere to all of the following requirements:

- Wear the appropriate personal protection equipment
- Handle all returned batteries with the same responsible care as new batteries
- Keep batteries upright at all times. Do not tip over on side or upside down (Except Non-Spillables)
- Do not drop batteries. Put batteries carefully down on skid/pallet
- Only lead-acid batteries may be returned
- Do not double stack cells or batteries on skid/pallet
- Terminals must be protected with non-conductive caps, tape or other insulating material (e.g. waffleboard, cardboard) to prevent shorting
- Total height of package not to exceed 1 1/2 times the skid/pallet width
- Any damaged or cracked cell must be free of electrolyte and placed in a heavyweight clear polyethylene plastic bag (min. 6 mil) that is securely closed.
- All vent caps must be in place

## IMPORTANT SKID/PALLET SPECIFICATIONS

- Use a skid/pallet provided with a new shipment to return used motive batteries if possible
- Maximum skid/pallet sizes: 48" x 44" or 48" x 40"
- Skid/pallet boards: 5/8 inch thick minimum preferred
- Skid/pallet must be constructed with a minimum of three bottom runners
- Skid/pallet sturdy and durable enough to handle the weight of battery load

Instructions courtesy of Battery Council International.

**EXIDE** Start Positive. Stay Positive.™

7



Information provided for reference only, please consult your Buyer or designated Transportation Specialist prior to shipment

# Packaging and Securing Flooded And Non-Spillable Stationary Cells

## INSTRUCTIONS FOR PREPARING USED NON-SPILLABLE STATIONARY CELLS FOR SHIPMENT

1. Place cells on skid/pallet that meets pallet specifications noted in this document. Use Triwall (3 Layer Cardboard) or Waffleboard between layers.
2. Place 1/2" plywood sheet on the top of pallet. Place your first layer of cells on top of the plywood. Place cells on their side to help avoid the possibility of them falling over during shipment. Place one layer of 5/8" Triwall or Waffleboard on the top of the first layer of cells. Place the next layer using the same guidelines. Continue building layers, making sure that you do not exceed maximum pallet weight. (See Step 1). Place Triwall or Waffleboard around ALL sides of the cells.
3. Secure the cells by nailing wooden cleats to the skid on all sides so the Triwall is held tightly against the cells and will remain vertical.
4. Install cardboard corner supports initially with packing tape to make it easier to manage before banding (See Step 2).
5. Install plastic banding<sup>2</sup> horizontally around each layer of cells as shown in drawing (Step 3). Before pulling tight, place wooden strips under the banding as shown to provide support for the cardboard. Note, the wooden strips can be held in place with packing tape to make it easier to manage before tightening the banding.
6. Once each layer has one horizontal band securing them, place 1/2" plywood on the top layer and secure with two bands vertically that run from front to back on the skid. Drill holes through cleating/skid boards as close to cells as possible and run banding through holes and around batteries to secure.
7. After you have completed banding, place the RSA tag on top of the pallet to complete preparation for shipping (See Step 4).

<sup>1</sup> Title 49 C.F.R. 173.159 Batteries, Wet

<sup>2</sup> PLASTIC BANDING SPECIFICATIONS:

- PREFERRED: 3/8" polyester strapping, 2500 lb break strength – utilizing friction weld, NOT clips
- LIGHT WEIGHT APPLICATIONS: 3/8" polyester strapping, 1400 lb break strength – utilizing friction weld, NOT clips
- ALTERNATIVE MATERIAL (Manual Application): 3/8" polyester composite strapping, 2000 lb break strength – buckle joint

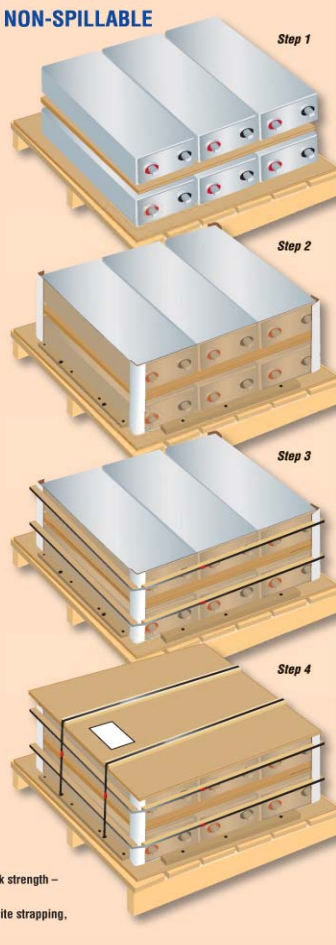

## INSTRUCTIONS FOR PREPARING USED FLOODED STATIONARY CELLS FOR SHIPMENT

- Cells must be palletized using a skid/pallet (See "Skid/Pallet Specifications" for details).
- Cells must be upright and secured with wooden cleats on skid/pallet.
- Cells must be banded with plastic banding<sup>2</sup> and a minimum of three horizontal bands and two vertical bands around cells are required.
- Adequate reinforcement (e.g. plywood) must be placed on the top and sides of the cells to prevent shorting, cutting or distortion.

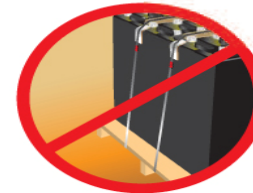
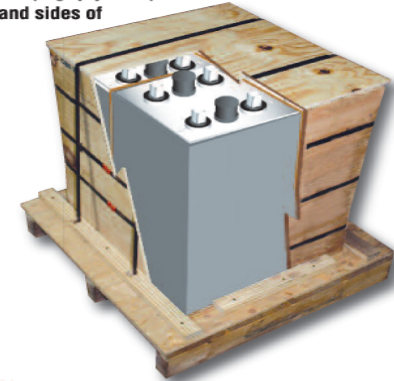

**NOTE:**

Do not run banding around the outside of skid boards to avoid the possibility of boards collapsing during shipment.

These Guidelines were developed by a committee of industry experts and are believed adequate to assure compliance with USDOT requirements effective as of December, 2010. However, especially if an incident occurs in transit, regulatory authorities may challenge the adequacy of your packaging and load securing notwithstanding your compliance with these Guidelines. Seek legal advice if you have any questions about these issues.

Instructions courtesy of Battery Council International.



# Packaging and Securing Used Motive Batteries/Cells

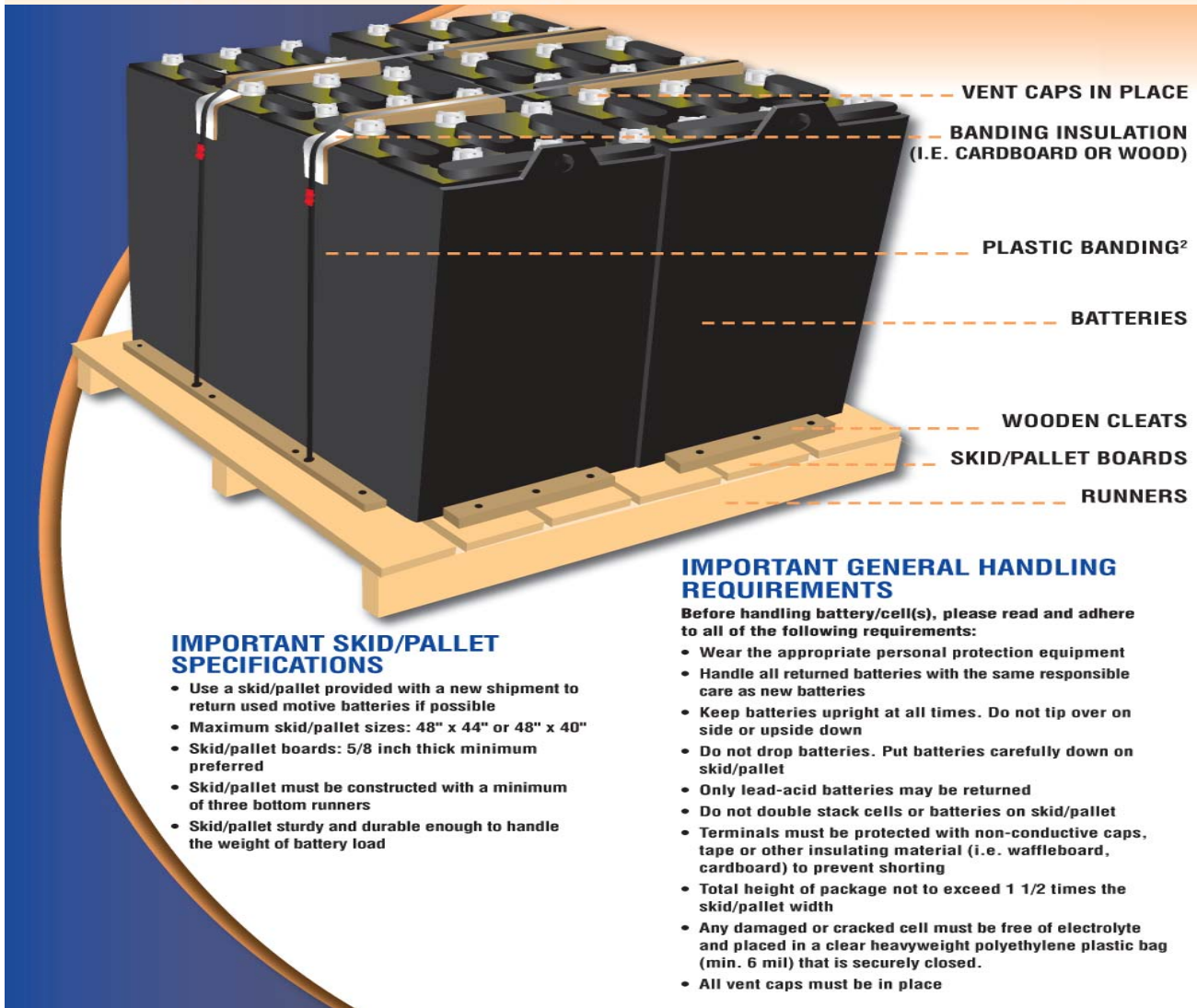

## IMPORTANT SKID/PALLET SPECIFICATIONS

- Use a skid/pallet provided with a new shipment to return used motive batteries if possible
- Maximum skid/pallet sizes: 48" x 44" or 48" x 40"
- Skid/pallet boards: 5/8 inch thick minimum preferred
- Skid/pallet must be constructed with a minimum of three bottom runners
- Skid/pallet sturdy and durable enough to handle the weight of battery load

## IMPORTANT GENERAL HANDLING REQUIREMENTS

Before handling battery/cell(s), please read and adhere to all of the following requirements:

- Wear the appropriate personal protection equipment
- Handle all returned batteries with the same responsible care as new batteries
- Keep batteries upright at all times. Do not tip over on side or upside down
- Do not drop batteries. Put batteries carefully down on skid/pallet
- Only lead-acid batteries may be returned
- Do not double stack cells or batteries on skid/pallet
- Terminals must be protected with non-conductive caps, tape or other insulating material (i.e. waffleboard, cardboard) to prevent shorting
- Total height of package not to exceed 1 1/2 times the skid/pallet width
- Any damaged or cracked cell must be free of electrolyte and placed in a clear heavyweight polyethylene plastic bag (min. 6 mil) that is securely closed.
- All vent caps must be in place

Instructions courtesy of Battery Council International.



# Packaging and Securing Used Motive Batteries And Used Motive Cells For Shipment

## INSTRUCTIONS FOR PREPARING USED MOTIVE BATTERIES FOR SHIPMENT

1. See "Important Skid/Pallet Specifications" Section.
2. Place all batteries upright and across the runners of the skid/pallet if possible.
3. Batteries must be free from leaks.
4. Multiple batteries can be banded together to consolidate a shipment to a standard skid/pallet size.
5. Adequate wooden cleats must be firmly nailed to the skid/pallet on all sides around the base of the battery(ies) perimeter, to prevent the battery from sliding off the skid/pallet during transport.



6. Batteries must be banded with plastic banding<sup>2</sup> and adequate insulation. See "General Handling Requirements" for details.



8. Each battery should be secured to the skid/pallet by:
  - Banding in one direction (See A in Fig.1) and wooden cleats nailed to skid/pallet on all four sides of the battery (See B in Fig. 1). Banding should be placed in the same direction as the runners of the skid/pallet (See C in Fig. 1). The banding should pass through the skid/pallet as close as possible to the base of the battery to keep the load from moving during transport.

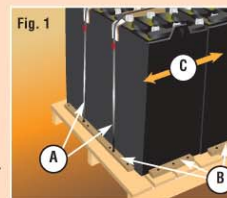

9. Skid/pallets must be properly blocked, braced, or otherwise secured in the trailer to prevent shifting of the load during transport.



**NOTE:**  
Do not pass banding around the outside edge of skid/pallet to avoid skid/pallet failure during transport.

These Guidelines were developed by a committee of industry experts and are believed adequate to assure compliance with USDOT requirements effective as of December, 2010. However, especially if an incident occurs in transit, regulatory authorities may challenge the adequacy of your packaging and load securing notwithstanding your compliance with these Guidelines. Seek legal advice if you have any questions about these issues.

<sup>1</sup> Title 49 C.F.R. 173.159 Batteries, Wet

<sup>2</sup> PLASTIC BANDING SPECIFICATIONS: PREFERRED: 3/4" polyester strapping, 2500 lb break strength – utilizing friction weld, NOT clips • LIGHT WEIGHT APPLICATIONS: 1/2" polyester strapping, 1400 lb break strength – utilizing friction weld, NOT clips • ALTERNATIVE MATERIAL (Manual Application): 3/4" polyester composite strapping, 2000 lb break strength – buckle joint

## INSTRUCTIONS FOR PREPARING USED MOTIVE CELLS FOR SHIPMENT

### SUPPORT BRACING METHOD: MULTIPLE CELL INSTRUCTION

- Cells must be palletized using a skid/pallet (See "Skid/Pallet Specifications" for details).
- Cells must be upright and secured with wooden cleats on skid/pallet.
- Adequate reinforcement (i.e. plywood) must be placed on the top and sides of the cells to prevent shorting, cutting or distortion.
- Cells must be banded with plastic banding<sup>2</sup> with a minimum of three horizontal bands and two vertical bands.

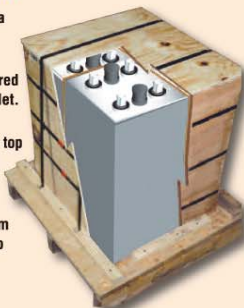

### ALTERNATIVE SUPPORT BRACING METHOD: MULTIPLE CELL INSTRUCTION

- Cells must be upright and secured with wooden cleats on skid/pallet.
- Cells must be banded with plastic banding<sup>2</sup> with a minimum of three horizontal bands and two vertical bands.
- Terminals must be protected with non-conductive caps, tape or other insulating material (i.e. waffleboard, cardboard) to prevent shorting
- Stretch wrap may be used for extra support

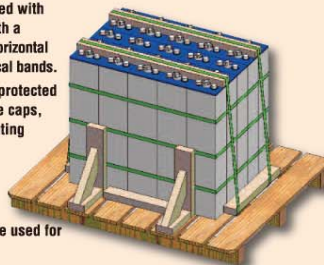

### SUPPORT BRACING METHOD: SINGLE CELL INSTRUCTION

- Cells must be palletized using a skid/pallet.(See "Skid/Pallet Specifications" for details).
- Cells must be upright and secured with wooden cleats on skid/pallet.
- Adequate reinforcement (i.e. plywood) must be placed on the top and sides of the cells to prevent shorting, cutting or distortion.
- Cells must be banded with plastic banding<sup>2</sup> with a minimum of three horizontal bands and two vertical bands.

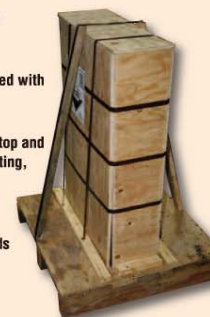

### ALTERNATIVE SUPPORT BRACING METHOD: SINGLE CELL INSTRUCTION

- Cells must be palletized using a skid/pallet (See "Skid/Pallet Specifications" for details).
- Use gusset support bracing on all four sides
- Terminals must be protected with non-conductive caps, tape or other insulating material (i.e. waffleboard, cardboard) to prevent shorting
- Cells must be banded with plastic banding<sup>2</sup> with two vertical bands across tops of cells.
- Cells must be palletized using a skid/pallet (See "Skid/Pallet Specifications" for details).

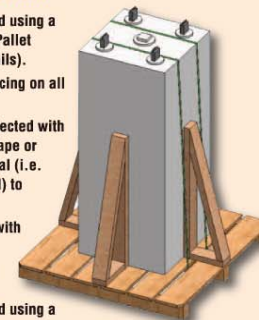

Instructions courtesy of Battery Council International.



# Auto 10201



**SLI, Commercial**



**AGM, Gel**

## Automotive

- May be received and processed at all Exide Recycling Centers.
  - These batteries have polypropylene cases.
  - Categories include all lead-acid auto, commercial, marine, RV, golf cart and motorcycle.
  - Auto-sized large sealed lead-acid rechargeable, emergency lighting and back up power/UPS.
- \* Military (6TL) size may not be received or processed in Vernon.

## Handling / Packaging

- Palletize for shipment three layers high using plastic shrink wrap to secure batteries to pallet. Golf cart, commercial and military should be palletized by type.
- Use cardboard between skid and each layer to act as both a shock absorber and to absorb liquid which may leak from cells. Cardboard must be on the top layer as well.
- Failure to comply may result in refusal by the Exide Recycling Center.

## Weight Guidance

- Approximate weight 21 lbs. – 117 lbs.



**Marathon™ M Range  
Sprinter® S Range**



**Powerfit™ S500 Range**



# Sealed Lead-Acid 10209



**Powerfit™ S300**



**Sonnenschein®**

## Sealed Lead-Acid

- Reading and Muncie may receive and process this material.
- Frisco, Vernon and Canon Hollow may receive this material in limited quantities. This material is consolidated and processed through other approved facilities.
- The case is not polypropylene.

## Handling / Packaging

- Palletize for shipment using plastic shrink wrap to secure cells to pallet.
- Battery must be protected against short circuits and or sparking by taping one terminal on each battery with electrical tape prior to stacking.
- Use cardboard between skids and cells to act as both a shock absorber and to absorb liquid which may leak from cells. Cardboard must be on the top layer as well.
- Stack three high with cardboard on bottom layer between skid and first row and cardboard between each layer as well as on the top layer.
- Must be removed from plastic housings or external metal racks if applicable.
- Failure to comply may result in refusal by the Exide Recycling Center.

## Weight Guidance

- Average weight is between 1 lb. and 30 lbs.



# Industrial Steel Case 10207



Titan®



Tubular- HP™

## Industrial Steel Case

- Muncie and Reading may receive and process this material.
- Canon Hollow, Frisco and Vernon may receive this material in limited quantities. This material is consolidated and processed through other approved facilities.
- This battery has a steel case with polypropylene jars.

## Handling / Packaging

- Palletize for shipment using plastic shrink wrap to secure batteries to pallet. Only non-metal banding is acceptable.
- Use cardboard between skids and batteries to act as a shock absorber and to absorb liquid which may leak from cells. Cardboard must be on the top layer as well.
- Failure to comply may result in refusal by the Exide Recycling Center.

## Weight Guidance

- Approximate weight 250 lbs. – 5,000 lbs.

## Common Nicknames

- These batteries also are called ironclad or forklift batteries



Fulpower™



GNB® Flooded Classic™



# Telephone / UPS 10208



Classic™ Energy Bloc



Marathon™ M FT

## Flooded Telecom and UPS (uninterruptible power supply)

- Reading and Muncie may receive and process this material.
- Frisco, Vernon and Canon Hollow may receive this material in limited quantities. This material is consolidated and processed through other approved facilities.
- The case is not polypropylene.

## Handling / Packaging

- Palletize for shipment using plastic shrink wrap to secure cells to pallet. Only non-metal banding is acceptable.
- Use cardboard between skid and cells to act as both a shock absorber and to absorb liquid which may leak from cells. Cardboard must be on the top layer as well.
- Do not stack these cells. They must be one single layer.
- Must be removed from external metal racks, if applicable.
- Failure to comply may result in refusal by the Exide Recycling Center.

## Weight Guidance

- Approximate weight 25 lbs. – 350 lbs.

## Common Nicknames

- These batteries also are called flooded cells and glass pack batteries.



# Industrial Cells 10255



**Used Cells**



**Industrial Cells**

## Industrial cells

- Reading and Muncie may receive and process this material.
- Frisco, Vernon and Canon Hollow may receive this material in limited quantities. This material is consolidated and processed through other approved facilities.

## Handling / Packaging

- Palletize for shipment using plastic shrink wrap to secure cells to pallet. Only non-metal banding is acceptable.
- Use cardboard between skid and cells to act as both a shock absorber and to absorb liquid which may leak from cells. Cardboard must be on the top of the cells as well.
- Do not stack these cells. They must be one single layer.
- Must be removed from external metal racks, if applicable.
- Failure to comply may result in refusal by the Exide Recycling Center.

## Weight Guidance

- Approximate weight 100 lbs. – 350 lbs.

## Common Nicknames

- These batteries also are called forklift cells, steel case cells.



# New Generation Absolyte® GP 10207

## Non-cadmium construction



**Absolyte® GP 50 G**

### New Generation Absolyte® GP

- Muncie and Reading may receive and process this material.
- Canon Hollow, Frisco and Vernon may receive this material in limited quantities. This material is consolidated and processed through other approved facilities.
- These batteries have a steel case with black polypropylene jars.
- This category includes New Generation, non-cadmium, Absolyte® GP.

### Handling / Packaging

- Palletize for shipment using plastic shrink wrap to secure batteries to pallet. Only non-metal banding is acceptable.
- Use cardboard between skid and batteries to act as a shock absorber and to absorb liquid which may leak from cells. Cardboard must be on the top layer as well.
- Must be removed from external metal rack, if applicable.
- Failure to comply may result in refusal by the Exide Recycling Center.

### Weight Guidance

- Approximate weight 250 lbs. – 5,000 lbs.

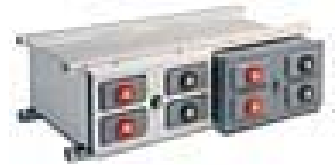

**Absolyte® GX2000**



**Element® Class I, II, III**



**Element® Deep Cycle Bloc**



# Industrial Absolyte® 10216

Original Construction (Cadmium-Bearing)



Absolyte® 6-90G15

## Absolyte®

- All Exide Recycling Centers may receive this material in limited quantities. This material is consolidated and processed through other approved facilities.
- This battery has a steel case with gray polypropylene jars.

## Handling / Packaging

- Palletize for shipment using plastic shrink wrap to secure batteries to pallet. Only non-metal banding is acceptable.
- Use cardboard between skid and batteries to act as a shock absorber and to absorb liquid which may leak from cells. Cardboard must be on the top layer as well.
- Must be removed from external metal rack, if applicable.
- Failure to comply may result in refusal by the Exide Recycling Center.
- **Exide may handle as a service, but does not provide any recovery value for these products.**

## Weight

- Approximate weight 250 lbs. – 5,000 lbs.



Absolyte® IIP



Absolyte® IIP  
5 Bank 24 Cell



Absolyte® GX



# Other Lead-Bearing Materials



**Lead Plates**  
**10252**



**Shot / Range Lead**  
**10405**



**Wheel weights**  
**10404**

- **10252 – Industrial plates.** This material may be considered hazardous waste, requiring a manifest, in many states. This material may be accepted in “roll offs” or dump trailers. Please research your local regulations prior to shipment.
- **10405 – Shot or range lead.** This material requires a “coffee can size” sample to be sent, in advance, to the appropriate Exide Recycling Center. The sample must be shipped to the attention of the Material Manager. Price and acceptance of this material will be based on the analysis. If purchased material does not meet the standards of original sample, loads may be downgraded or rejected and returned to the shipper at the originator’s expense.
- **10404 – Wheel weights.** This material may be shipped to all Exide Recycling Centers.
- Each of these materials may be shipped in 55 gallon drums or bulk containers (Gaylord boxes) that are secured to a pallet with several layers of shrink wrap. The Provider's name and phone number must appear on all paperwork and containers.



# Other Lead-Bearing Materials



**Scrap Lead 10403**



**Ship Keel /Ballast  
10407**



**Other Remelt  
10407**

- **10403 – Scrap lead** may be shipped to all Exide Recycling Centers.
- **10407 – Remelt grade lead** (95% lead or higher). An assay is required to determine pricing.
- **Lead bars, ingots, strips, sheets**, etc. may be classified as either scrap lead or remelt grade lead based on the assay.
- If an assay is not available, a sample must be sent to the Exide Recycling Center for analysis. Price and acceptance of this material will be based on the analysis.
- Material shipped in bulk containers (Gaylord boxes) must be secured to a pallet with several layers of shrink wrap. The Provider's name and phone number must appear on all paperwork and containers.



**Lead Ingots**

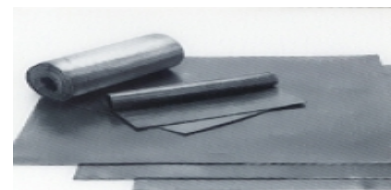

**Sheet Lead**



**Clean Cable Lead  
10407**



***Exide is proud to be the preferred choice for the recycling of your spent lead-acid batteries and other lead-bearing materials.***

***For further information, please contact your Exide Battery Representative or Authorized Distributor.***

***You also may reach us:***

***1-800-START-IT (1-800-782-7848)***

***Or at Exide.com***

